

IsoFlex Flexible Disc Couplings: Installation of the '6000 - series'

(Also see: 'IsoFlex Flexible Disc Couplings: Installation Notes.')

STEP 1. [Important Note: If the alignment and coupling installation is carried out while the vessel is supported out of the water, the alignment must be rechecked with the vessel in the water]

Loosen the gearbox and propeller shaft flange bolts and separate the flanges so that the alignment of the flanges can be checked using a feeler gauge.

Align the flanges using the adjusting studs of the engine mounts to within 0.003"[0.07mm], with measurements taken around the circumference of the flanges.

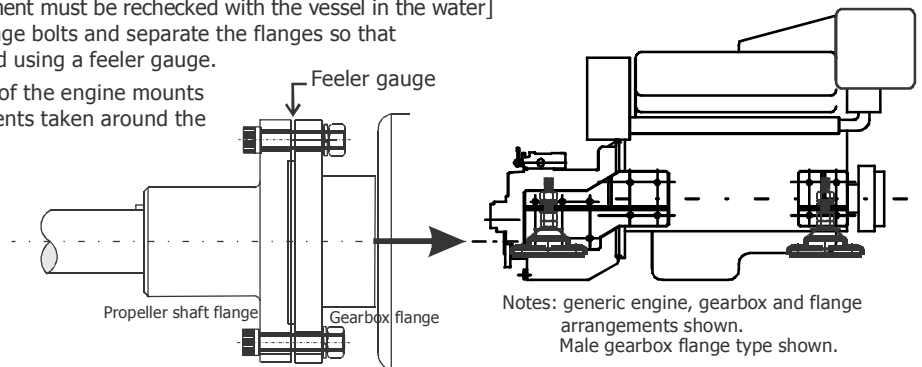

STEP 2.

Remove the flange bolts and part the flanges, fit the coupling to the gearbox output flange by mating the spigots and rotating the coupling to align the drive bushes of the coupling with the flange holes.

Fit the bolts, nuts & spring washers supplied, tightening to the required torque in two steps in the sequence shown. (ie: for a required torque of 70Nm, tighten to 35Nm in the sequence shown then to 70Nm in the same sequence.)

Important Note: It is critically important to measure the spigot depths and heights to ensure that there is a minimum clearance of 0.020"(0.5mm), ie: none of the spigots shall ever 'bottom out'.

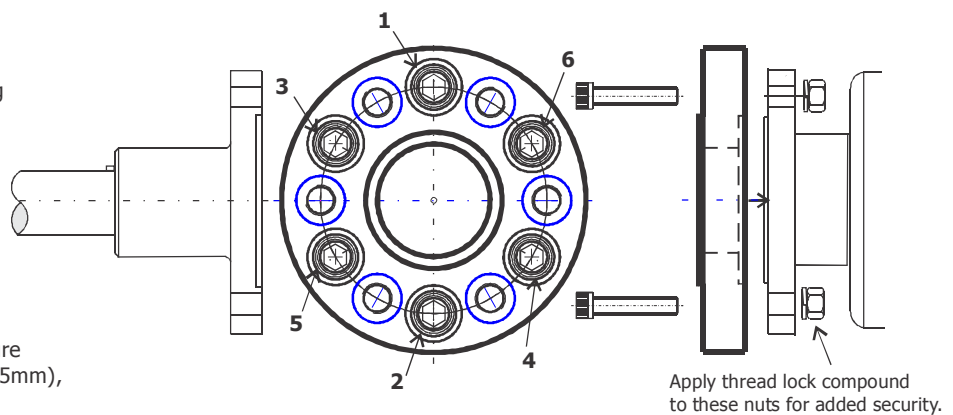

STEP 3.

Fit the propeller shaft flange to the coupling by mating the spigots and rotating the flange to align the flange holes with the threaded inserts of the coupling.

To ensure easy removal of the bolts for future alignment checks, apply a thin layer of waterproof grease before fitting.

Fit the bolts & spring washers supplied, tightening the bolts using the same procedure and sequencing as in Step 2. - see diagram.

Note: It is advisable to check for run-out at this stage. Slowly rotate the shaft by hand with a dial indicator on the gearbox output flange then the propeller shaft flange. (a run-out of approx 0.004" [0.1mm] is acceptable for most power transmission applications)

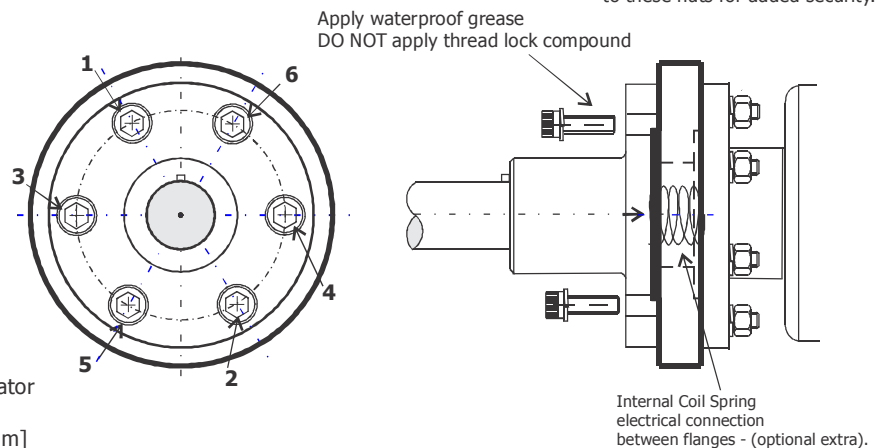

Important Note:

IsoFlex polymer disc couplings electrically isolate the propeller & shaft from the engine & gearbox.

To ensure a secure electrical connection from the engine to the shaft and propeller, an internal coil spring (optional extra) may be fitted as shown above.

STEP 4.

Check coupling for heat build-up after 2 hours of sea-trials. If the coupling is noticeably hotter than the gearbox flange, this is an indication that a misalignment is still present and this needs to be rectified to avoid any damage to the machinery.

Step 5.

Re-check bolts for tightness after approximately 15 hours of operation.

